

## Safety Precautions

This is a sophisticated radio controlled model that must be operated with caution and common sense. Failure to operate your Mini-T in a safe and responsible manner could result in damage to the model and property. The Mini-T is not intended for use by children without direct adult supervision. Team Losi and Horizon Hobby shall not be liable for any loss or damages, whether direct, indirect, special, incidental, or consequential, arising from the use, misuse, or abuse of this product or any product required to operate it.

- This model is controlled by a radio signal that is subject to interference from many sources outside your control. This interference can cause momentary loss of control so it is advisable to always keep a safety margin in all directions to avoid collisions.
- Always operate your model in an open area away from cars, traffic and people.
- Never run out into the street for any reason.
- Never run your Mini-T with low transmitter batteries.
- Carefully follow the directions and warnings for this and any optional support equipment (chargers, re-chargeable battery packs, etc.) that you use.
- Keep all chemicals, small parts and anything electrical out of the reach of children.

## Required Equipment

12 AA size Alkaline batteries, 8 for the transmitter and 4 for the model.

## Tools and Items You Will Find Handy

- Soft bristle brush for cleaning
- A 5.5mm nut driver for the wheel nuts.
- A #0 or #1 Phillips screwdriver
- A LOSA99100 .050" Allen Wrench

Note: Use only Team Losi tools or other high quality tools. Use of inexpensive tools can cause damage to the small screws and parts used on this type of model.

## About the Radio System

The following is an overview of the Mini-T's radio system and it's various functions and adjustments. Since Mini-T operates on a radio signal that you control, it is important that you please read and understand about all of these functions and adjustments before driving.

- 1. Steering Wheel:** Controls direction (left/right) of the model.
- 2. Throttle Trigger:** Controls speed and direction (forward/reverse) of the model.
- 3. Antenna:** Transmits signal to the model.
- 4. On/Off Switch:** turns the power on for the transmitter operation.
- 5. Indicator Lights:** Green (top) light indicates adequate battery power. Red (bottom) indicates signal strength.
- 6. ST. TRIM:** adjusts the "hands off" direction of the model
- 7. TH. TRIM:** adjusts the motor speed to stop at neutral.
- 8. Steering Rate:** adjusts amount front wheels move when the steering wheel is turned left or right.
- 9. ST. REV:** reverses the function of the steering when the wheel is turned left or right.
- 10. TH. REV:** reverses the function of the speed control when pulled back or pushed forward
- 11. Bottom Cover & Battery Tray:** covers and holds the batteries that power the transmitter
- 12. Transmitter Crystal:** determines frequency/channel you transmit on. The receiver must have a matching frequency/channel to operate.

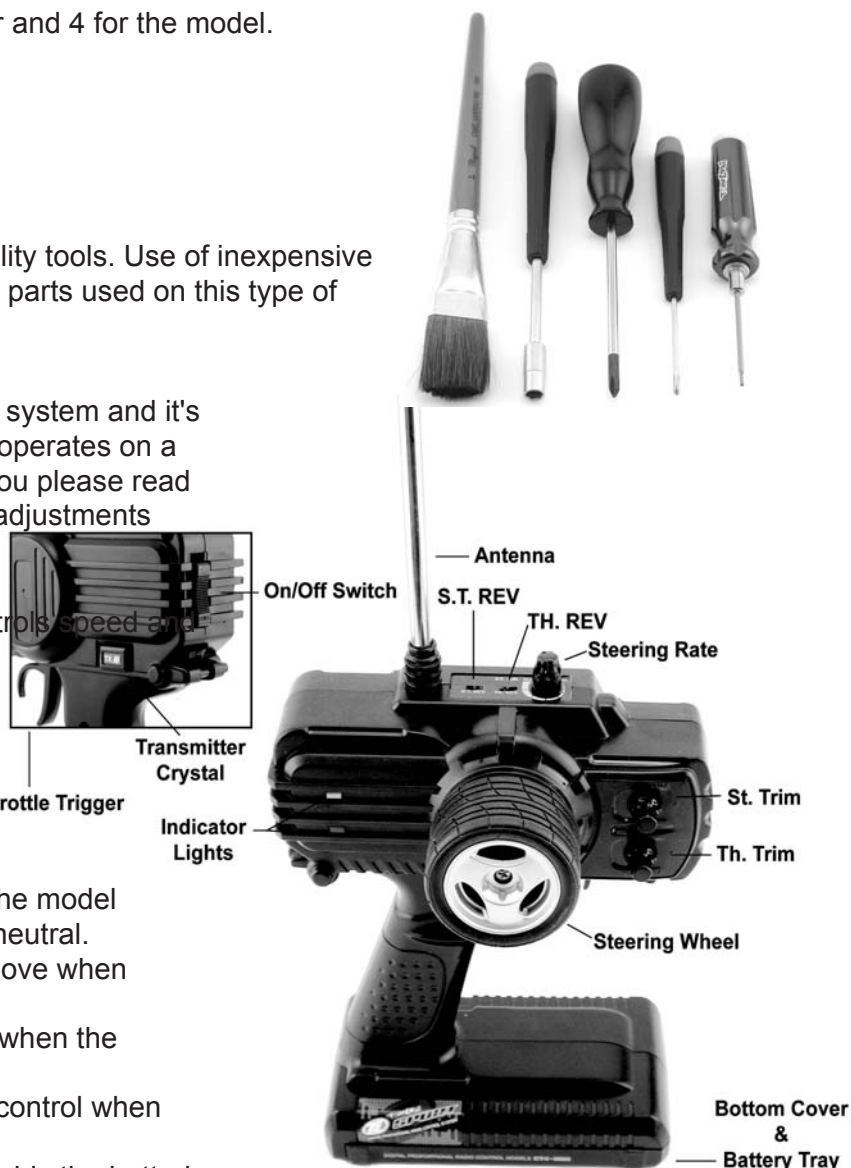

### **The Receiver/Speed Control**

- 1. Receiver:** receives the signal from the transmitter to control the model.
- 2. Receiver Crystal:** determines which channel it will receive.
- 3. On/Off Switch:** controls power to the receiver.
- 4. Antenna Mast:** receives the signal from the transmitter.
- 5. Power Plug:** connects battery pack to the receiver/speed control.
- 6. Steering Servo:** controls steering movement.
- 7. Steering Servo Plug:** receiver connection and power supply.
- 8. Electronic Speed Control:** controls power and direction of the motor.
- 9. Motor Plugs:** power connection from the speed control.

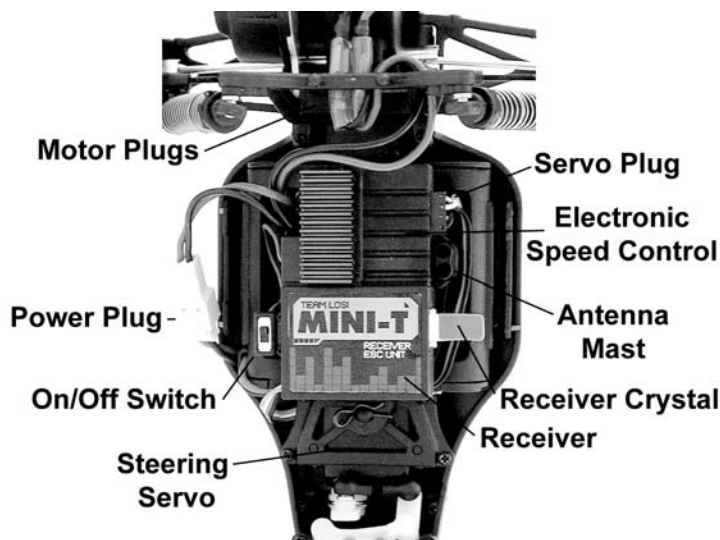

### **Changing Frequencies/Channels**

The Mini-T radio operates on 27mhz and has 6 different frequencies/channels available. Simply put, a frequency is like a TV channel. The transmitter you hold in your hand is like the TV station and the model with the matching crystal is like your TV tuned exclusively to the channel of the station. The Mini-T radio is equipped with changeable crystals that allow you to change the frequency/channel you operate on. This is especially useful when you want to run a group of Mini-T's at the same time. When changing crystals/channels you must always replace the crystals as a set with one going in both the transmitter and the receiver in the truck. Each of the 6 different channels are numbered and color-coded. Each set includes a unique crystal for the receiver marked (RX) and one for the transmitter marked (TX). The crystals are changed by gently pulling them out, then lining up the two pins of each crystal with its socket, carefully pushing the new crystals into place. **DO NOT** force them as damage can occur. **If they do not slide into the socket easily check for bent or misaligned pins.**

Channel 1	Brown	26.995 MHz	(LOSB1094)
Channel 2	Red	27.045 MHz	(LOSB1095)
Channel 3	Orange	27.095 MHz	(LOSB1096)
Channel 4	Yellow	27.145 MHz	(LOSB1097)
Channel 5	Green	27.195 MHz	(LOSB1098)
Channel 6	Blue	27.255 MHz	(LOSB1099)

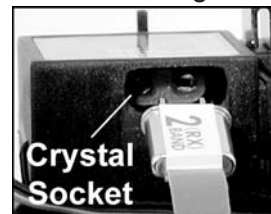

### **Making Adjustments**

The following are simple adjustments and easily maintained settings that will assure proper operation and performance. Since the Mini-T comes from the factory with optimum settings we suggest first-time R/C drivers leave these as they are and simply maintain them as necessary. Only after gaining experience should new drivers try experimenting with different settings.

### **Chassis Tuning**

The Mini-T has several adjustments available to you for tuning the performance for your needs. Although there are multiple shock positions and camber link locations provided, as noted above we have built the model with the best overall settings. The following are simple adjustments and easily maintained settings that will assure proper operation and performance. It is advised that when making any adjustment you do so in small increments and always check for other parts of the chassis that are affected.

### **Slipper Adjustments**

The Mini-T is equipped with a slipper device that offers both traction control and protection for the transmission. The slipper is primarily used to help absorb sudden impacts on the drive train due to landing big jumps or when using more powerful aftermarket motors and/or battery packs. Additionally, it can be used to smooth out the flow of power to the rear wheels and limit wheel spin when running on extremely slick surfaces. Adjustment is made by turning the 3mm adjustment nut clockwise (to the right) to reduce the slip or counterclockwise (to the left) to increase the slip.

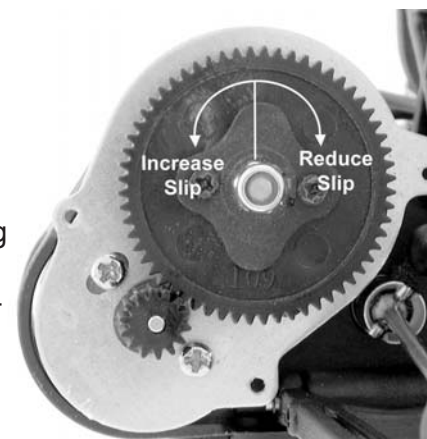

Continued on next page.....

When adjusted properly, you should be able to hold the rear tires firmly and barely be able to push the spur gear forward with your thumb. To track test, turn the Mini-T on and place it on the ground. As you push it backwards allowing it to roll freely, punch the throttle. The slipper should slip no more than an inch or two as it accelerates. With a stock motor and 4 cell battery it will probably not slip at all. With a 5 or 6 cell battery pack it should slip just a little. Make sure you replace the gear cover before running.



### **Steering Rate**

Your transmitter is equipped with a steering rate control at the top right. This advanced feature, usually found only on competition type radios, allows you to adjust the amount the front tires move when you turn the steering wheel. This is really helpful when you are on slick as well as high traction surfaces. If your Mini-T turns too sharply and/or spins out easily, try turning the steering rate down by rotating the knob counter-clockwise (to the left). For sharper or additional steering try turning the knob clockwise (to the right).

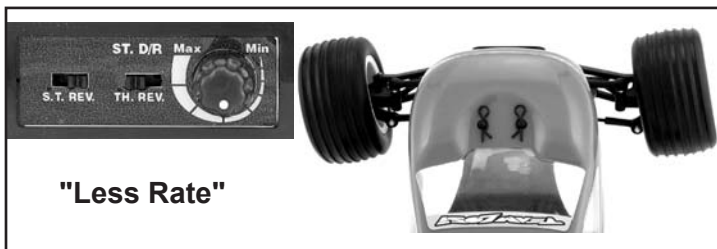

### **Camber**

Camber is the angle of the tires to the racing surface when viewed from the front or rear of the truck. You want to keep both the front and rear tires straight up and down or leaning in at the top very slightly. If you are running on carpet or similar high traction surfaces you may find leaning them in a bit more helps. This adjustment is made with the threaded links that extend from the front or rear bulkhead to the spindle carrier or rear hub. Making these shorter increases the camber and lean-in of the tire while making them longer decreases the camber.

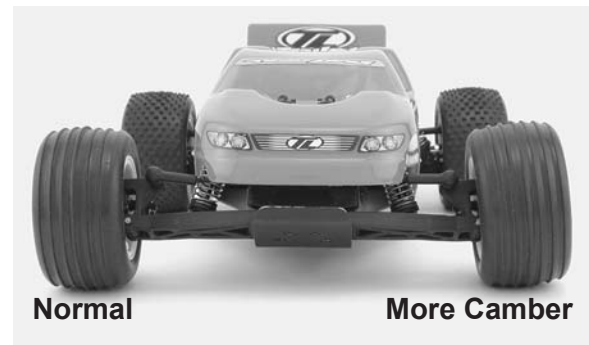

### **Toe-In**

This is the relationship of the left and right side tire to one another. Ideally you want the front of the tires to be pointed inward toward each other just slightly when viewed from above. This makes the model track straight and stable. This is controlled with the threaded steering rods on either side. As you make them longer you will increase the toe-in and vice versa.



### **Ride Height**

This is the height the chassis sits and runs at. There are spring spacers included with the Mini-T that, when installed between the shock top and spring, will increase the pre-load on the spring and raise the chassis. You may want to try this when running on extremely rough surfaces.

## Option Parts

Team Losi as well as other manufactures offer optional "hop-up" parts in two categories, performance and appearance. When choosing appearance parts you must take into consideration the impact that these parts can have on both performance and durability. As an example, chrome plated plastic wheels will have no effect on performance but look cool. Aluminum wheels will look even cooler but will increase both rotating and unsprung mass, which will greatly hinder performance. They will also increase the possibility of bending axles and breaking arms if raced hard. Performance parts on the other hand replace existing parts and perform a function either differently or better for a particular application like competition and racing. Choose wisely to achieve your *goal*. The option parts you should consider that will offer the greatest boost to performance are:

- *Ball Bearings for the front wheels and rear hubs* (LOS1100)
- *Oil filled shock absorbers* (avail. soon)
- *Rechargeable Ni-Cad pack* (see your dealer)
- *Ball differential (for racing)* (avail. soon)

## Service/Repair

**Radio/Speed Control & Motor:** If you have any problems other than those covered in the troubleshooting section please call the **electronics service dept.** at **(877) 504-0233**. They will be able to give your specific problem additional attention and instruct you as to what needs to be done.

**Chassis:** If you have any questions other than those covered in the troubleshooting or maintenance sections please call **(909) 390-9595**. Please note that this is for the chassis only and the personnel at this number will probably not be able to answer additional questions about the electronics.

**Cleaning:** Performance can be hindered if dirt gets in any of the moving suspension parts. Use compressed air, a soft paintbrush, or toothbrush to remove dust or dirt. Avoid using solvents or chemicals as they can actually wash dirt into the bearings or moving parts as well as cause damage to the electronics.

**Rebuilding the differential:** The gears in the differential will wear over time. The same is true for the outdrives, driveshafts, and rear axles. We suggest using a small rag or paper towel to layout the parts you remove to make it easier to reassemble.

1) Unplug the motor. 2) Remove the gear cover (three screws). 3) Remove the motor guard screws at the top of the transmission and the two at the extreme rear bottom of the chassis. 4) Remove the screw that attaches the rear shock tower to the transmission and the 4 screws at the bottom of the chassis that hold the gearbox in place and slide it out of the chassis 5) Remove the left side of the gearbox by removing the three screws. 6) Remove any shims on the bevel gears and set them aside so they can be re-installed in the same location. 7) Carefully remove the large plastic sun gear and the bevel gears on either side of it. You can use the removed differential assembly as a guide for putting together the replacement unit (a little Team Losi Teflon grease #LOSA3066 can be applied for even better performance). 8) Remove the center mounted idler gear from the gearbox. Remove the shaft and push out the ball bearings from either side. Install these bearings in the new gear. **Re-assembly:** Replace the idler gear and shaft into the center of the same right side of the gearbox. Replace any shims removed from the right bevel gear and slide it thru the lower bearing. Replace any shims that came off of the left side bevel gear and allow it to slide through the lower bearing as you put the left gear box half back into position.

Replace the screws and re-install the rebuilt gearbox using the steps in reverse order that were used to remove it.

## Changing the Spur Gear

Remove the gear cover by removing the three small screws. If you are replacing the spur gear with one that is a different size (number of teeth) you must first loosen (do **not** remove) the two screws that secure the motor and slide it back slightly. Remove the 3mm nut at the end of the slipper shaft and all of the slipper parts on the outside of the spur gear as well as the old gear. Place the new spur gear into position and replace the slipper parts. If you have changed the size of the spur see setting the gear mesh explained elsewhere. After you have changed the spur gear you will have to adjust the slipper as described elsewhere.

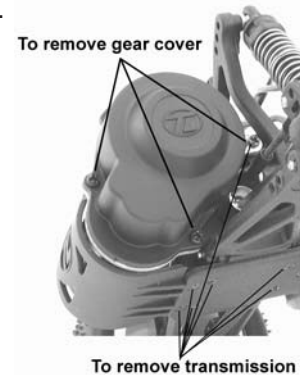

### ***Changing the Pinion Gear/Gear Ratio***

Before you change the pinion gear ask yourself why you are doing it. In general, if you change to a larger pinion the top speed will improve but you will see less acceleration and run time. This would only be advisable for really long track layouts with few tight turns. Changing to a smaller pinion will give you quicker acceleration and possibly a bit longer run time but a little less top speed. This would be good for real short layouts or when running hotter motors. The pinion that is on the Mini-T offers the best balance of both. To change the pinion remove the gear cover, loosen the motor screws, and slide the motor back. Use a pair of small needle nose pliers between the motor plate and back of the pinion to push the pinion off. Place the new pinion on the end of the motor shaft and using the flat of the pliers or a similar flat tool, push it on to the same position as the one removed. If you have changed the size of the spur see setting the gear mesh below. **Warning:** When running after-market motors, check with the motor Manufacture for correct gearing. Never over gear the motor as it can cause overheating, damaging it and the speed control.

### ***Setting The Gear Mesh***

The motor screws should be slightly loose. Slide the motor forward allowing the pinion gear to mesh with the spur gear. Snug (not tight) the bottom motor screw and try rocking the spur back and forth. There is a slight bit of movement before the motor is forced to turn over. If not, pull the top of the motor back slightly and recheck. If there is too much slop between the gears push the top of the motor forward. When set properly the wheels can be spun forward freely with very little noise. Make sure to tighten both motor screws and replace the gear cover before running.



### ***Radio Replacement/Service***

If you have a radio problem please call **(877) 504-0233 for customer service**. Most likely unless you have gotten the components wet the service technician can help you fix the problem over the phone. If the problem is more severe you may be asked to send in the truck and transmitter or the entire radio system, which would include the receiver/speed control unit and steering servo. In some cases, like a broken servo or a speed control that has failed due to getting wet, your local dealer can sell you the re-placement component. The following is complete guide to removing the system.

### ***Steering Servo***

Unplug the servo lead from the left side of the receiver. Remove the four small screws that secure the servo mount/chassis brace to the chassis. Use a screwdriver or small pliers to pop the steering link off of the servo and it is free to be removed. There is no need to remove the servo mounts on either side as all service can be done with them on. Replace in the reverse sequence used to remove it.



### ***Receiver/Speed Control (ESC)***

Unplug the power lead, motor leads and steering servo. Carefully remove the antenna wire from the antenna tube. Do not attempt to open the receiver or electronic speed control (ESC) as only a factory technician has the proper tools and parts to make any repairs necessary. The receiver/esc unit is mounted with double-sided foam tape. Use your thumb and index finger at the bottom of the front corners to pull the receiver/esc unit from the mount. If this is difficult ask for help. If necessary, carefully use a large flat blade screwdriver between the unit and the mount to pry it loose. Make sure you remove any left over foam or adhesive before remounting with common servo tape or hobby type foam tape.



## **Service/Tech Help**

**All electronics (877) 504-0233**

**Chassis (909) 390-9595**

# Mini-T Trouble Shooting Guide

Doesn't operate	Battery not charged or plugged in No crystal in receiver No crystal in transmitter Receiver switch not "on" Transmitter not "on" or low battery	Charge battery / plug-in Check and replace if necessary Check and replace if necessary Turn on receiver switch Turn on / replace batteries
Motor runs but rear wheels don't move	Pinion not meshing with spur gear Pinion spinning on motor shaft Slipper too loose Transmission gears stripped Drive pin in axle missing	Adjust pinion/spur mesh replace pinion gear on motor Check & adjust slipper Replace transmission gears Check & replace
Steering doesn't work	Servo plug not in receiver Servo gears or motor damaged	Check if plug in / all the way Replace or repair servo
Won't turn one direction	Servo gears damaged	Replace servo gears
Motor doesn't run	Motor plugs loose Motor wire broken ESC damaged	Plug-in completely Repair or replace as needed <b>Call Electronics Tech</b>
ESC gets hot	Motor over geared Driveline bound up	Put smaller pinion on motor Check wheels & trans for binds
Poor run time and/or sluggish Acceleration	Batteries low Ni-Cad pack not fully charged Charger not allowing full charge Slipper slipping too much Motor worn out Driveline bound up Wheel and axle bushings worn	Replace "AA" cells in truck Recharge Try another charger Check/adjust slipper Replace motor Check wheels & trans for binds Replace with ball bearings
Poor range/glitches	Transmitter battery low Transmitter antenna loose Battery low in truck Loose plugs or wires	Check & replace as necessary Check & tighten Replace or recharge Check motor and power plugs
Slipper won't adjust	Drive pin missing in shaft Spur gear face worn out	Replace drive pin Replace spur gear & adjust slipper
Wheels wobble/shake	Bushings worn out	Replace with ball bearings

# XXX

JUST BECAUSE YOU DON'T WANT TO BUILD,  
DOESN'T MEAN YOU SHOULDN'T HAVE THE BEST.

# SPORT ART

Each Team Losi ready to run machine benefits from the same race proven features found in its kit built counterpart and the sophistication of a JR computer radio control system. No bushings, only bearings. No plastic where there was aluminum. No stripped down radio system. No compromise.

# NO COMPROMISE

## ENGINEERING WINS



### LOS40880 XXX-NT SPORT ART

Crowned the 2002 Nitro Truck of the Year by the editors of RC Car Action magazine, the XXX-NT Sport boasts a JR programmable control system, an aircraft aluminum chassis, low stacked 4.11:1 ratio transmission, and ball bearings everywhere. Its tough suspension with its hard-anodized oil filled shocks is on par with anything you would find in much more expensive kits. The potent Mach .15 engine will have you blasting down the straights at a blistering 40 mph making you more than a match for any sportsman class competition right out of the box.



### LOS40280 XXX-S SPORT ART

Based on the same platform that took home the ROAR Stock National Sedan Championship, the XXX-S Sport features a JR programmable control system, a sealed, single-belt drivetrain with easy access differentials, MIP CVD driveshafts for smooth, solid power transmission and an integrated one-piece chassis that allows you to use either stick or saddle style battery packs. And as with every other Losi ready to run, ball bearings are used throughout. Plenty of power is provided by the racing quality 19-turn, rebuildable motor with GM Racing's V3R electronic speed control. Quite simply, this is the finest ready-to-run electric sedan you can buy.



### LOS40090 XXX-T SPORT ART

The XXX-T Sport uses the same race proven platform that has won numerous ROAR National Championships. This includes the exclusive XXX-T suspension system with hard-anodized oil filled shocks, ball bearings from wheels to tranny, a rigid molded chassis with a dropped center that lowers the CG and improves handling, and a fully adjustable slipper clutch that lets you tweak traction and acceleration control to track conditions. Add a JR programmable control system and the power of a racing quality 19-turn motor mated with GM Racing's state-of-the-art V3R electronic speed control and you've got a ready-to-run electric truck that doesn't just exceed your expectations, it redefines them.



# TEAM LOSI MINI-T

800-0218  
Effective:  
10/1/2003

**1/18TH SCALE RTR VERSION OF THE CHAMPIONSHIP WINNING XXX-T**

## PRICE LIST EXPLODED VIEW



Team Losi

A Division of Horizon Hobby, Inc.,  
4710 E. Guasti Rd, Ontario, CA 91761  
[www.TeamLosi.com](http://www.TeamLosi.com) / [feedback@TeamLosi.com](mailto:feedback@TeamLosi.com)



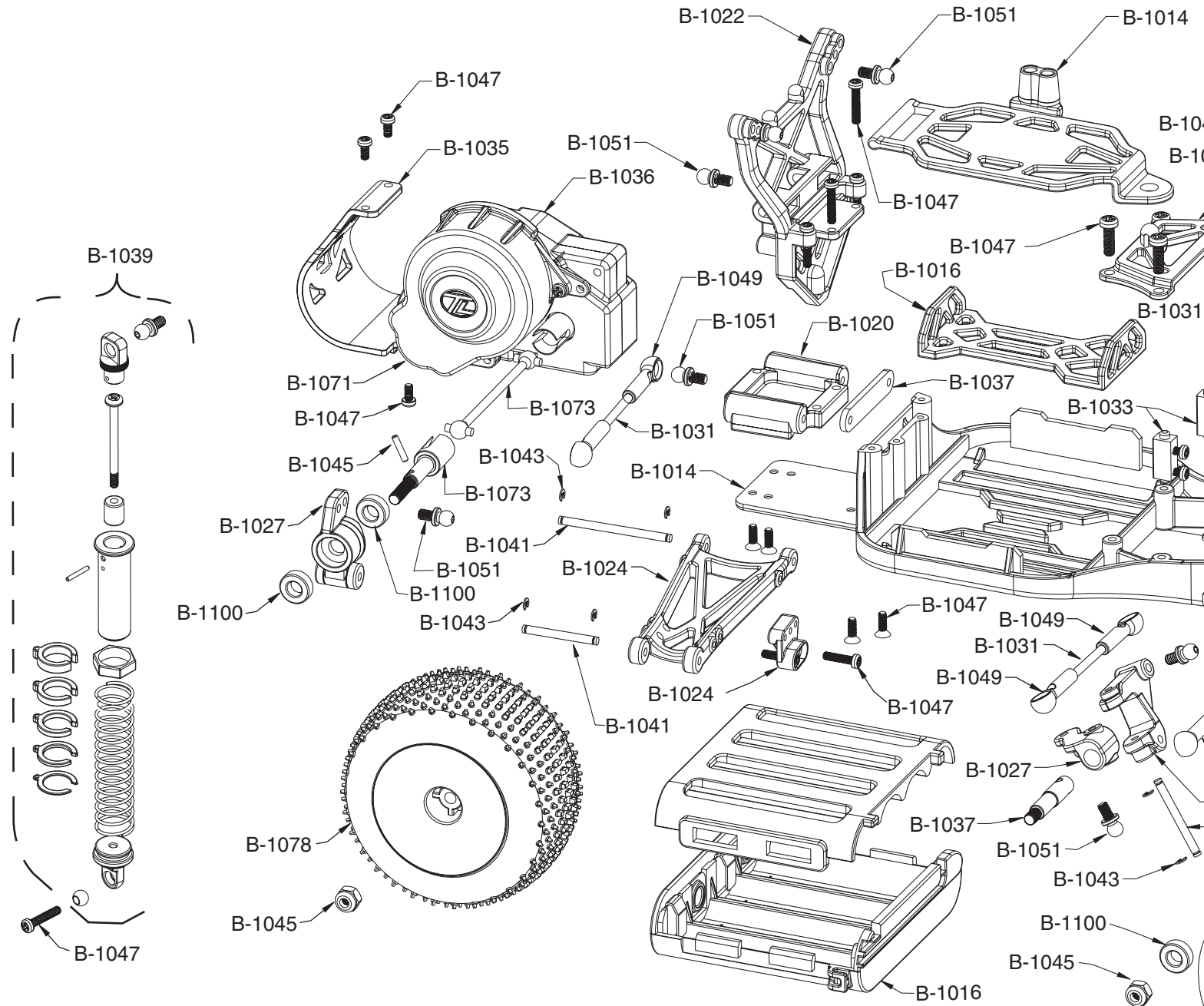

NOT RESPONSIBLE FOR TYPOGRAPHICAL ERRORS

ALL PRICES SUBJECT TO CHANGE WITHOUT NOTICE

LOSB1001	Mini-T Painted & Trimmed Body - Silver .....	\$18.99	LOSB1029	Steering Set .....	\$4.00
LOSB1002	Mini-T Painted & Trimmed Body - Blue .....	\$18.99	LOSB1031	Camber and Steering Link Set .....	\$2.00
LOSB1003	Mini-T Painted & Trimmed Body - Red .....	\$18.99	LOSB1033	Servo Mount & Steering Pin Set .....	\$2.50
LOSB1004	Mini-T Painted & Trimmed Body - Black .....	\$18.99	LOSB1035	Front Bumper & Motor Guard Set .....	\$7.00
LOSB1005	Mini-T Painted & Trimmed Body - Yellow .....	\$18.99	LOSB1037	Front Axle & Pin Brace Set .....	\$5.00
LOSB1006	Mini-T Painted & Trimmed Body - Purple .....	\$18.99	LOSB1039	Damper Set (4) Assembled .....	\$14.99
LOSB1008	Mini-T Clear Body w/Masks & Stickers .....	\$11.99	LOSB1041	Suspension Pin Bag .....	\$4.00
LOSB1010	Mini-T Sticker Sheet .....	\$4.50	LOSB1043	E-Clip Bag .....	\$1.50
LOSB1011	Mini-T number Sheet .....	\$1.50	LOSB1045	Wheel Nuts & Drive Pins .....	\$2.00
LOSB1012	Mini-T Jump Ramps (4) .....	\$7.00	LOSB1047	Complete Screw Set .....	\$2.00
LOSB1014	Main Chassis Set .....	\$6.00	LOSB1048	Body Clips (10) .....	\$1.50
LOSB1016	Battery Box Set .....	\$4.50	LOSB1049	Rod End Set (14) .....	\$3.00
LOSB1018	Front Bulkhead, Kickplate & Brace .....	\$4.00	LOSB1051	Ball Stud Set (10) .....	\$5.00
LOSB1020	F/R Pivot Block Set .....	\$3.00	LOSB1058	Transmission Case & Motor Plate Set .....	\$9.00
LOSB1022	F/R Shock Tower Set .....	\$4.00	LOSB1060	Transmission Ball Bearing Set (7) .....	\$19.99
LOSB1024	F/R Suspension Arm Set .....	\$5.00	LOSB1062	Transmission Shaft Set .....	\$6.00
LOSB1027	Spindle, Carrier & Hub Set .....	\$4.00	LOSB1064	Slipper Hardware Set .....	\$4.00



# GETTING STARTED

**NOTE:** Before you start running your new Mini-T, it is absolutely necessary that you read through all of the operating instructions to get the maximum enjoyment and prevent unnecessary damage.

## Step 1

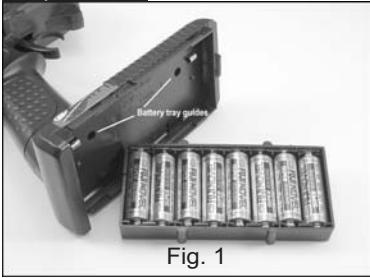

Remove the transmitter battery tray by sliding the bottom cover. Install eight (8) AA alkaline batteries into the battery holder. Pay close attention to the correct direction of the positive (+) and negative (-) ends as marked in the tray. Reinstall the battery tray using the molded pegs in the bottom as a guide for the correct location and replace the bottom cover.

## Step 4



Remove the battery box top by lightly prying the bottom rail of either end of the retaining clip. Install four (4) AA alkaline batteries into the battery box, again paying close attention to the correct direction of the cells. Replace the cover and make sure the retaining clips snap over the rails at either end.



## Step 2

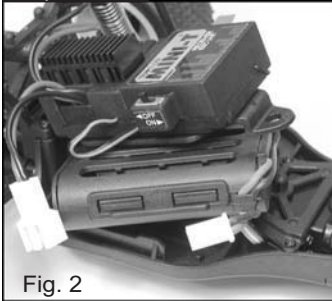

After removing the body, remove the small hatch pin just in front of the receiver above the steering servo. Carefully swing the plate with the receiver/speed control upward and remove the battery box.

## Step 5



Install the battery box with the plug at the right front corner. Let the receiver/speed control plate drop over the batteries onto the mounting post and replace the hatch pin that secures it in place. Plug in the battery using the slots and bars molded into the plugs as a guide and you are ready to go!



## Step 7

Turn on the Mini-T by sliding the switch on the right side of the receiver forward (Fig. 5.) as noted on the side of the switch. If the rear wheels turn, adjust the "TH. TRIM" knob (Fig. 8) located to the lower right of the steering wheel until they stop. To go forward pull the trigger back. If you should need reverse, wait for the model to stop then push the trigger forward. When going forward the model should move in a straight line. If not, adjust the "ST. TRIM" (Fig. 8) so that it tracks in a straight line without having to turn the steering wheel.

After you are done running, turn the Mini-T off **FIRST** by sliding the switch toward the back of the truck (Fig. 5). After the model has been turned off, turn off the transmitter (Fig. 6). If you wish to clean your Mini-T, use compressed air and / or a soft paintbrush to remove dust and dirt. **NEVER** use chemicals or anything wet as it can cause damage to both the electronics and plastic parts.

## ALWAYS

- Turn on the transmitter before the truck
- Use caution when running around people
- Turn both the Mini-T and transmitter "off" when done
- Check the battery condition of the transmitter before running.

## NEVER

- Operate the Mini-T with low battery power.
- Run the Mini-T through water or wet grass
- Use chemicals to clean the chassis
- Run the Mini-T without a gear cover

## Step 3

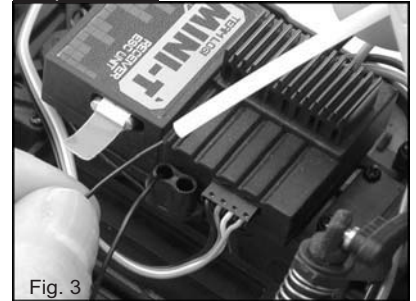

Insert the antenna wire through the antenna mount and into the antenna tube pushing it through until it comes out the other end. Push the antenna tube into the antenna mount.

## Step 6

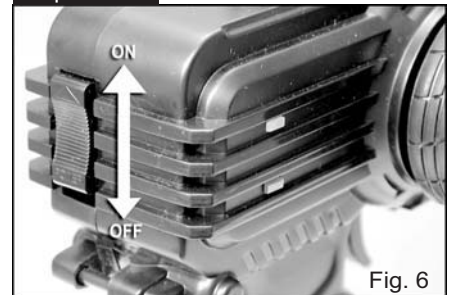

**Always** turn on the transmitter first by sliding the switch on the left side upward. The small red and green lights to the left of the steering wheel should both light up. If not you need to check for low or incorrectly installed batteries.